

Description: A modular plug-and-play LED Stair Lighting System designed for surface installation on mono-beam stairs. Designed and built with high-CRI LED's, the system is guaranteed to offer great light distribution and highlight the texture and finish of your stairs. Manufactured to your exact measurements and specifications.

Features:

- ◆ System designed to **increase safety** and provide a visually appealing illumination
- ◆ Light Source: **LED Strip, high CRI**
- ◆ **Solid state** connections eliminate the risk of oxidation over time
- ◆ Suitable for **surface installation**, indoor use only
- ◆ **Five correlated color temperature options** or **RGB**
- ◆ Can be controlled by **low voltage motion sensors** only
- ◆ All system components carry certification markings for the North American market

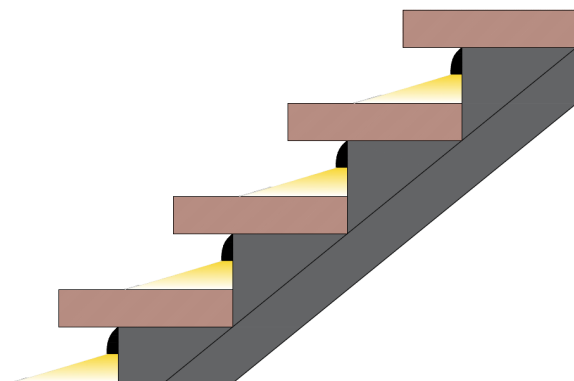
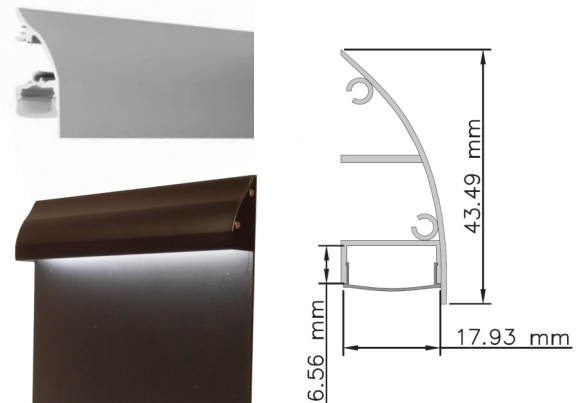

Note: All specification sheets are subject to change without notice. Please fill out the bottom section of this page and return to us by email for a free quote.

Model	Correlated Colour Temperature (CCT)			Power consumption	Dimming option
DMBS-S	2700K	3000K	3500K	4.5 W/ft	Dimmable
	4000K	6000K	RGB		Non-dimmable
Number of motion sensors (optional)				Standard luminaire length of 169 mm (6 10/16 inches) OR Custom luminaire length—please specify	